

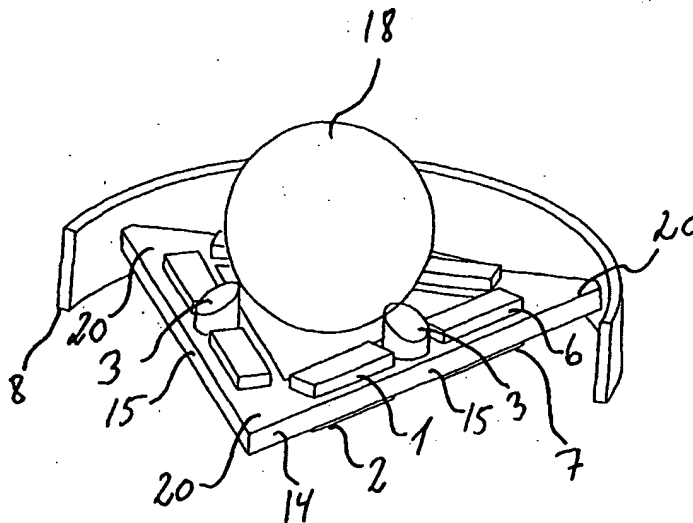

INTERNATIONAL APPLICATION PUBLISHED UNDER THE PATENT COOPERATION TREATY (PCT)

(51) International Patent Classification ⁷ : H01L 41/09, H02N 2/00	A1	(11) International Publication Number: WO 00/30186 (43) International Publication Date: 25 May 2000 (25.05.00)
<p>(21) International Application Number: PCT/DK99/00626</p> <p>(22) International Filing Date: 16 November 1999 (16.11.99)</p> <p>(30) Priority Data: PA 1998 01486 16 November 1998 (16.11.98) DK</p> <p>(71)(72) Applicants and Inventors: ANDERSEN, Brian [DK/DK]; Vilsundvej 29, DK-9220 Aalborg Ø (DK). BLANKE, Mogens [DK/DK]; Skovbakken 23, DK-3520 Farum (DK). HELBO, Jan [DK/DK]; Ferskenvej 14, DK-9000 Aalborg (DK). SMIRNOV, Arkadii Borisovich [RU/RU]; Bolschaya Zelenina Street, 14/18, flat 85, St.Petersburg, 197110 (RU). YEROFEYEV, Anatoly Aleksandrovich [RU/RU]; Polytechnicheskaya Street, House 17/3, Flat 168, St.Petersburg, 194021 (RU). YEROFEYEV, Sergey Anatoljevich [RU/RU]; Polytechnicheskaya Street, House 17/3, flat 172, St.Petersburg, 194021 (RU).</p> <p>(74) Agent: PATRADE A/S; Aaboulevarden 21, DK-8000 Aarhus C (DK).</p>	<p>(81) Designated States: AE, AL, AM, AT, AT (Utility model), AU, AZ, BA, BB, BG, BR, BY, CA, CH, CN, CR, CU, CZ, CZ (Utility model), DE, DE (Utility model), DK, DK (Utility model), DM, EE, EE (Utility model), ES, FI, FI (Utility model), GB, GD, GE, GH, GM, HR, HU, ID, IL, IN, IS, JP, KE, KG, KP, KR, KZ, LC, LK, LR, LS, LT, LU, LV, MA, MD, MG, MK, MN, MW, MX, NO, NZ, PL, PT, RO, RU, SD, SE, SG, SI, SK, SK (Utility model), SL, TJ, TM, TR, TT, TZ, UA, UG, US, UZ, VN, YU, ZA, ZW, ARIPO patent (GH, GM, KE, LS, MW, SD, SL, SZ, TZ, UG, ZW), Eurasian patent (AM, AZ, BY, KG, KZ, MD, RU, TJ, TM), European patent (AT, BE, CH, CY, DE, DK, ES, FI, FR, GB, GR, IE, IT, LU, MC, NL, PT, SE), OAPI patent (BF, BJ, CF, CG, CI, CM, GA, GN, GW, ML, MR, NE, SN, TD, TG).</p> <p>Published <i>With international search report. Before the expiration of the time limit for amending the claims and to be republished in the event of the receipt of amendments.</i></p>	

(54) Title: VIBRATION ACTUATOR



(57) Abstract

A vibration actuator with multiple degrees of freedom comprising one or more stators (14) and a spherical moving member (18). The stator (14) comprises a number of resonators (15), preferably three arranged in a triangle, with a driving force output member (3) attached to and projecting from each resonator (15). A number of piezoelectric elements (1, 6) are attached to the surface of the resonator (15) to generate a motion of the driving force output members (3) to cause a relative motion of the spherical moving member (18). The impressed driving voltage for the excitation of the piezoelectric element (1, 6) is a sum of partial voltages, where each partial voltage excites a bending vibration of the resonator.

FOR THE PURPOSES OF INFORMATION ONLY

Codes used to identify States party to the PCT on the front pages of pamphlets publishing international applications under the PCT.

AL	Albania	ES	Spain	LS	Lesotho	SI	Slovenia
AM	Armenia	FI	Finland	LT	Lithuania	SK	Slovakia
AT	Austria	FR	France	LU	Luxembourg	SN	Senegal
AU	Australia	GA	Gabon	LV	Latvia	SZ	Swaziland
AZ	Azerbaijan	GB	United Kingdom	MC	Monaco	TD	Chad
BA	Bosnia and Herzegovina	GE	Georgia	MD	Republic of Moldova	TG	Togo
BB	Barbados	GH	Ghana	MG	Madagascar	TJ	Tajikistan
BE	Belgium	GN	Guinea	MK	The former Yugoslav Republic of Macedonia	TM	Turkmenistan
BF	Burkina Faso	GR	Greece	ML	Mali	TR	Turkey
BG	Bulgaria	HU	Hungary	MN	Mongolia	TT	Trinidad and Tobago
BJ	Benin	IE	Ireland	MR	Mauritania	UA	Ukraine
BR	Brazil	IL	Israel	MW	Malawi	UG	Uganda
BY	Belarus	IS	Iceland	MX	Mexico	US	United States of America
CA	Canada	IT	Italy	NE	Niger	UZ	Uzbekistan
CF	Central African Republic	JP	Japan	NL	Netherlands	VN	Viet Nam
CG	Congo	KE	Kenya	NO	Norway	YU	Yugoslavia
CH	Switzerland	KG	Kyrgyzstan	NZ	New Zealand	ZW	Zimbabwe
CI	Côte d'Ivoire	KP	Democratic People's Republic of Korea	PL	Poland		
CM	Cameroon	KR	Republic of Korea	PT	Portugal		
CN	China	KZ	Kazakstan	RO	Romania		
CU	Cuba	LC	Saint Lucia	RU	Russian Federation		
CZ	Czech Republic	LJ	Liechtenstein	SD	Sudan		
DE	Germany	LK	Sri Lanka	SE	Sweden		
DK	Denmark	LR	Liberia	SG	Singapore		
EE	Estonia						

Vibration actuator

BACKGROUND OF THE INVENTION

5 The present invention relates to a vibration actuator as described in the descriptive part of claim 1. The invention relates further to a method for generating a vibration in an elastic member.

10 Actuators to generate mechanical torque are usually single axes devices. These single axes devices can be combined in cases where torque is needed in two or three dimensions. However, the result is often heavy and expensive equipment.

15 A different type of actuator is disclosed in US-patent with no. 5,872,417. The described actuator is a vibration actuator that is compact and capable of motion around multiple axes. The vibration actuator includes a vibration element having drive force output members, and a relative moving member having a curved surface. The curved surface contacts the drive force output member to generate relative motion of the relative moving member with respect to the vibration element. The vibration element includes a frame shaped elastic member having the drive force output members attached thereto, and having electromechanical converting elements, usually piezoelectric elements, contacting the elastic member. When the electromechanical converting elements are excited by a drive voltage, vibrations are generated in the elastic member to produce a drive force which is transmitted to the relative moving member via the drive force output members. The vibration element can be controlled to generate relative motion in various directions by selectively controlling the electromechanical converting elements which are excited by a drive voltage.

20

25

30 The electromechanical converting elements are excited by voltages to achieve in the drive output force members a combination of two kinds of vibration, a longitudinal vibration parallel with the plane containing the points of contact between the driving force output members and the relative moving member, and a bending vibration in a

direction intersecting the plane. The longitudinal and bending vibrations are combined to generate an elliptical motion of the output members.

5 In the described actuator, longitudinal vibrations in the plane of the frame shaped elastic member are damped, because these vibrations induce substantial mechanical deformation of the frame shaped elastic member. Therefore, it would be desirable, if it were possible to avoid longitudinal vibrations in such a device. In connection with this argument, it shall be pointed out here that generating bending vibrations in such a device is far more efficient than longitudinal vibrations.

10

SUMMARY OF THE INVENTION

It is an object of the present invention to provide a vibration actuator having multiple degrees of freedom which comprises only bending vibrations in the elastic member to generate driving movements of the driving force output members.

15

According to the present invention, this is achieved by a vibration actuator mentioned by way of introduction characterised in that the excitation of the electromechanical converting elements generates a vibration which is a sum of partial vibrations, where each partial vibration is a bending vibration. Preferably, the vibration is a sum of vibrations in the first and the second bending mode.

20

Longitudinal vibrations are omitted. This way, the actuator according to the present invention is far more effective than likewise actuators of prior art. As will become apparent from the explanation in the detailed description below, excitation of bending modes only is sufficient to move the relative moving with multiple degrees of freedom.

25

The relative motion member may have a spherical shape or be shaped as part of a sphere.

30

The actuator comprises a number of elastic elements, each of the elastic members comprises at least two electromechanical converting elements. Preferably, the elastic elements comprises four electromechanical converting elements arranged in pairs on each side of the elastic member. The electromechanical converting elements are preferably piezoelectric elements. The elastic elements can be made of any elastic material, for example metal, glass, plastic, or a composite material

The driving force output member on the elastic member is according to a further embodiment of the invention located between two electromechanical elements that are located on one side of the elastic member.

The shape of the vibration element according to a further embodiment of the invention is polygonal, preferably triangular. Each side of the polygon comprises an elastic member. The locations for the connections between the elastic members coincide with the location of nodes of the wave-formed bend of the elastic members during the bending vibration. This implies the advantage that the mutual influence of the resonators on their individual motion is very small and consequently, they can be treated as independent in a mathematical model. For the optimum design of the actuator, this is a great advantage leading to more precise results than if the resonators would influence each other. Also, a simple, yet precise, model is an advantage when implementing a model based feedback control system.

In order to stabilise the relative moving member on the vibration element, the actuator in a further embodiment of the invention comprises a compression element, that presses the relative moving member against the driving force output member. This is also a way to avoid that the relative moving member, preferably a sphere, falls out of the actuator. Furthermore, the friction between the surface of the relative moving member and the driving force output members can be increased.

According to a further embodiment of the invention, a second vibration element is comprised by the actuator, wherein the second vibration element is arranged on the

opposite side of the relative moving member and arranged parallel to the first vibration element.

5 A further advantage of the present invention is a general method of generating vibrations in a plate shaped elastic member where at least two electromechanical converting elements are attached to a surface of the elastic member, the electromechanical converting elements being excited by impressing driving voltages thereon to generate the vibration of the elastic member, wherein the vibration of the elastic member is a sum of partial vibrations, where each partial vibration is a bending vibration. Preferably the
10 partial vibrations are in the first and second bending mode. The method is general in that it is applicable in other devices than vibration actuators, however, the application in a vibration actuator is preferred

BRIEF DESCRIPTION OF THE DRAWINGS

15

These and other objects and advantages of the invention will become apparent and more readily appreciated from the following description of the preferred embodiments, taken in conjunction with the accompanying drawings, of which:

20

Fig.1 shows a simple form of a resonator,

Fig.2 shows a piezo resonator with four piezo elements,

Fig.3 illustrates the first mode bending of a resonator,

Fig.4 illustrates the second mode bending of a resonator,

Fig.5 illustrates the figure-8 curve motion of the end part of the contact tip,

25 Fig.6 is an oblique view of a vibration actuator in accordance with one embodiment of the invention,

Fig.7 illustrates, how the contact tip exerts force on the sphere,

Fig.8 illustrates in detail the motion of the contact tip and the exerted force on the sphere,

30 Fig.9 is a top view of the actuator with an indication of the motions of the contact tips which causes the sphere to rotate around the fourth axis,

Fig.10 shows a circuit of a drive for a multiple degrees of freedom vibration actuator,

Fig.11 is a side view of an actuator in another embodiment of the invention showing the stator, the sphere, and a compression member,

Fig.12 is an oblique view of an actuator in a still another embodiment of the invention,

Fig.13 is a side view of an actuator in a further embodiment of the invention comprising two compression members and two stators,

Fig.14 is a side view of an actuator in a still further embodiment of the invention comprising four stators .

DETAILED DESCRIPTION OF THE PREFERRED EMBODIMENT

Without loss of generality in the following, the vibration element is called stator, the electromechanical converting element is called piezo element, the elastic member in combination with the piezo elements is called resonator, and the driving force output member is called contact tip.

Furthermore, the stator will be explained from the point of view, where the stator is triangular. However, a quadrangular or other polygonal shapes are possible.

FIG. 1 illustrates in a simple form the principle of a resonator with piezo elements. A piezoelectric ceramic element 1 is attached to the upper side of an elastic member 4. A constant voltage applied vertically across the upper piezo element 1, the voltage being in the same direction as the internal polarisation in the piezo element 1, will cause the upper element 1 to contract so that the elastic member 4, which is fastened to a support 5, bends and moves the tip 3 at the end of the elastic member 4 upwards. The force on the elastic member is increased, if a second piezo element 2 is used in combination with the first element 1. When simultaneously a constant voltage is applied vertically across the lower piezo element 2, the voltage being in the opposite direction of the internal polarisation of the lower piezo element 2, the lower piezo element expands so that the bending force is increased.

If the voltages are reversed, the elastic member 4 will bend downwards. By applying a sinusoidal input voltage $U(t)=U_0\sin(2\pi f \cdot t)$, where t is the time and U_0 is an amplitude,

the driving part with the tip 3 will bend up and down with frequency f . If this frequency equals the resonant frequency of the elastic member 4 with the piezo elements 1, 2, the deflection will increase by a certain factor called the quality factor.

5 FIG. 2 shows a piezo resonator with four piezo elements 1, 2, 6, 7 arranged in pairs. If a voltage is applied between the left two piezo elements 1, 2 and the right two piezo elements 6, 7, the elastic member 4 will be bend in a way determined by the force exerted on the elastic member 4.

10 Referring now to FIG. 3, the elastic member 4 is supported at its ends by a support 8. Assuming that all piezo elements 1, 2, 6, 7 have an internal polarisation in the same direction, the elastic member 4 in the resonator will bend up 9 or down 10, if the applied voltage U_A across the left pair of piezo elements 1, 2 is equal to the voltage U_B applied to the right pair 6, 7. This situation is called first bending mode. If the voltage
15 $U_A=U_B$ is alternating, the contact tip 3 will move up and down. If, however, the voltage applied across the left pair 1, 2 is opposite the voltage applied to the right pair 6, 7, $U_A=-U_B$, the elastic member 4 will bend 11 as shown in FIG. 4. This situation is called second bending mode. In this case, the contact tip 3 will turn around a turning point 12 in the centre of the resonator, so that the upper end 13 of the tip moves from
20 side to side.

The two bending modes can be combined into a complex bending mode by applying voltages to the left 1, 2 and right 6, 7 piezo elements that result from summing two sinusoidal voltages. The left and right voltages can be expressed as
25 $U_A(t)=U_1\sin(2\pi f_1 \cdot t)+U_2\sin(2\pi f_2 \cdot t)$ and $U_B(t)=U_1\sin(2\pi f_1 \cdot t)-U_2\sin(2\pi f_2 \cdot t)$, respectively. The situation of FIG. 3 is obtained for $U_2=0$ and the situation of FIG. 4 is obtained for $U_1=0$. For $U_1 \neq 0$ and $U_2 \neq 0$, the end of the tip 13 will move on a so-called Lissajous curve. In case that $f_2/f_1=2$, the curve will have form as a figure-8. This is explained in more detail in connection with FIG. 5 showing voltage U_2 corresponding to the second
30 bending mode excitation and voltage U_1 corresponding to the first bending mode excitation. The dots in the figure-8 curves show the positions of the tip at different times t . At time t_1 , both voltages are 0 and therefore, the tip is in the centre of the figure-8

curve. At time t_2 the increase of U_2 forces the tip to turn to the left and U_1 forces the tip upwards. At time t_3 , U_2 is zero and does not excite the tip, U_1 is at maximum and forces the tip to the highest position. At time t_4 the decrease of U_2 forces the tip to turn to the right, U_1 is decreasing thus lowering the tip. At time t_5 both U_2 and U_1 are zero and thus, the tip will be in the centre of the figure-8 curve. At time t_6 , the increase of U_2 forces the tip to turn to the left and U_1 forces the tip downwards. At time t_7 , U_2 is zero and does not excite the tip, U_1 is at minimum and forces the tip to the lowest position. At time t_8 , the decrease of U_2 forces the tip to the right, U_1 is increasing and thus, rising the tip. At time t_9 , the tip has returned to the initial position of the cycle.

10

The resonator is characterised by its resonance frequencies f_{r1} and f_{r2} , where f_{r1} corresponds to a resonance in first bending mode and f_{r2} corresponds to a resonance in the second bending mode. By choosing the driving frequencies f_1 and f_2 such that $f_1=f_{r1}$ and $f_2=f_{r2}$, an optimal activation of the first and second bending mode is obtained.

15

Normally, the ratio between the resonances f_{r2}/f_{r1} differs from 2, so it is not possible at the same time to fulfil all three conditions $f_2/f_1=2$, $f_1=f_{r1}$ and $f_2=f_{r2}$. Therefore usually in resonance conditions, the end of the contact tip will not move on a curve which has a form like a figure-8. However, the condition $f_2/f_1=2$ can be achieved without serious loss of performance. Mathematical models are normally used to find the optimal way of exciting the resonators. As these mathematical models only approximate the actual situation to a certain degree, it is of advantage if the physical system can be modelled with a relatively simple but yet precise model.

20

FIG. 6 is an oblique view of a vibration actuator in accordance with a first embodiment of the invention. A triangular stator 14 comprising three resonators 15 which are plate shaped and constitute the sides of the stator, forms the base for the relative moving member 18, which in this case is a sphere. The moving member 18, however, could also be only a part of a sphere, and furthermore, it could be hollow or solid.

25

Each of the resonators 15 comprises two pairs of piezo elements 1, 2 and 6, 7 in between of which a contact tip 3 is localised. The sphere 18 is resting on the three con-

30

tact tips 3. For contact between the sphere 18 and the stator, a three point connection is optimum.

5 For mounting the stator, a supporting ring 8, half of which is shown on figure 1, can be used, where the supporting ring 8 is attached to the stator at the nodes of the vibrations in the resonator. The supporting device can have other shapes than a ring, as long as it supports the stator at the vibrational nodes.

10 In operation while using the first and second bending mode, the connections 20 between the resonators 15 are at the nodes of the bend. This implies that the mutual influence of the resonators 15 on their motion is small and consequently, they can be treated as independent in a mathematical model. For the optimum design of the actuator, this is a great advantage, because it is possible to make a precise model, since the physical system is relatively simple. In other words, it is possible and easier to make a
15 precise model than if the resonators would influence each other.

With reference to FIG. 7, the motion of the sphere 18 is explained in case when the resonators are excited in the first mode and the contact tip 3 moves up and down. Applying this vibration to the sphere will force the sphere to rotate. FIG. 7a through FIG.
20 7d show how the sphere is forced to rotate about the second axis when the resonator is excited in the first mode. A likewise explanation applies to rotations about the first and third axes.

In FIG. 7a, the contact tip 3 is moving up towards the sphere 18, but it is not in contact
25 with the sphere. In FIG. 7b, the contact tip 3 is still moving up and is in contact with the sphere 18. The contact tip 3 acts on the sphere 18 with a force F_r which can be decomposed into two forces: F_t and F_n . The force F_n provides the necessary friction and F_t provides the driving force. In FIG. 7c the contact tip 3 has moved further up. Since the contact tip is in contact with the sphere, the contact tip 3 is forced to bend. In
30 FIG. 7d the tip now moves down. The force F_n will no longer provide the necessary friction and thus, the contact tip 3 will not follow surface of the sphere 18 any longer.

Another way of explaining the motion of the contact tip is given by FIG. 8. The contact tip 3 comes in contact with the surface 21 of the sphere 18 at point A. At that point, it has a tangential velocity which is lower than the tangential velocity (v_t) of the sphere. The contact tip 3 is then accelerated so that the tangential velocity of the contact tip 3 is equal to the tangential velocity (v_t) of the sphere. This happens at point A'. After this, the contact tip 3 exerts force on the surface 21 of the sphere because of friction with a velocity equal to v_t . At point B' the contact tip 3 gradually loses its frictional grip until it separates from the surface 21 at point B.

When one or more of the resonators is excited in the combined vibration mode the sphere will rotate about the 4. axis. FIG. 9 is a top view of the vibration actuator. The applied voltages are chosen such that the vibration pattern of the contact tips 3 are curves formed like a figure-8. The voltages are furthermore chosen such that the contact tips 3, when they reach the upper part of their figure-8 motion, move in the direction as indicated with arrows 22 in FIG. 9 and thereby forcing the sphere 18 to rotate about the fourth axis, which is the axis orthogonal to the plane of the triangular stator.

FIG. 10 shows a circuit of a drive for a multiple degrees of freedom vibration actuator, wherein drive voltages are impressed on the respective sets of piezoelectric elements 1a, 1b, 1c, 6a, 6b, 6c.

As shown in FIG. 10, an oscillator 31 generates a sinusoidal voltage with frequency f_1 and an oscillator 32 generates a sinusoidal voltage with frequency f_2 . The voltage from oscillator 31 is input to electric summation amplifiers 36a and 36b. The voltage from oscillator 32 is connected or disconnected to the following circuit via a switch 33. The output from switch 33 is branched to an 180 degrees phase shifter 34 and to a rotation-direction switch 35. The output from phase shifter 34 is also input to the switch 35. The two outputs from the switch 35 are inputs to the electric summation amplifiers 36a and 36b. The outputs from the summation amplifiers is input to high voltage amplifiers 37a and 37b. The output from the amplifiers are inputs to three resonator-selection switches 38a, 38b, 38c.

The outputs from switch 38a is input to piezo elements 1a and 6a. Similarly the outputs from switches 38b and 38c are input to piezo elements 1b, 6b and 1c, 6c. Thus, switching resonator-selection switch 38a to the ON state, connects the resonator 15a to the voltage source. In this way switch 38a, 38b, 38c can be switched to the ON or OFF state and thus, connect or disconnect resonators 15a, 15b, 15c to the voltage source.

Rotation about the fourth axis is generated in the following way. Switch 33 is switched to the upper state so that both voltages from oscillator 31 and 32 are applied to the resonators. With switch 35 in the upper state, summation amplifier 36a will generate the signal $U1 \sin(2\pi f_1 \cdot t) + U2 \sin(2\pi f_2 \cdot t)$ and summation amplifier 37b will generate the signal $U1 \sin(2\pi f_1 \cdot t) - U2 \sin(2\pi f_2 \cdot t)$. The signals are amplified to high voltage signals via amplifiers 37a and 37b. By switching one, two or all resonator-selection switches to the ON state, the relative moving member 18 is forced to rotate about the fourth axis. By switching the rotation-direction switch 35 to the lower state, the summation amplifier 36a will generate the signal $U1 \sin(2\pi f_1 \cdot t) - U2 \sin(2\pi f_2 \cdot t)$ and summation amplifier 36b will generate the signal $U1 \sin(2\pi f_1 \cdot t) + U2 \sin(2\pi f_2 \cdot t)$, thus forcing the relative moving member 18 to rotate about the fourth axis but in a direction opposite to the direction when the rotation-selection switch is in the upper state.

Rotation about the first axis is generated in the following way. Switch 33 is switched to the lower state so that only the voltage from oscillator 31 is applied to the resonators. The summation amplifiers 36a and 36b will generate the signals U1. Resonator-selection switch 38a is switched to the ON state and switch 38b and 38c are switched to the OFF state. Thus, only resonator 15a is excited and the relative moving member 18 is forced to rotate about the 1. axis.

Similarly by switching the resonator-selection switch 38b to the ON state and switch 38a and 38c to the OFF state, the relative moving member is forced to rotate about the second axis. By switching resonator-selection switch 38c to the ON state and switch 38a and 38b to the OFF state forces the relative moving member to rotate about the third axis.

It can be advantageous to be able to regulate the press of the sphere against the contact tips in order to control the friction. A possible configuration is shown in FIG. 11. The sphere 18 is located between the stator 14 of the actuator and a compression member
5 23 in the form of a low friction ball bearing. Both the stator and the compression member can be spring loaded 24, 25 as shown in the figure. However, it suffices to spring load only one of the two components 14, 23. Spring loading has the advantage to achieve an approximately constant force with which the sphere 18 is pressed against the contact tips 3, irrespective of eventual tolerances in the parts making up the actua-
10 tor. It is necessary in the design of the actuator, however, to choose springs that do not exhibit any state of resonance during the working of the resonator.

FIG. 12 shows still another embodiment of the invention. In this case, two stators 14 are used to fix the sphere 18 in the centre between the stators. The mounting rings 8
15 with the stators 14 can be spring loaded to achieve an approximately constant force between the sphere 18 and the contact tips 3.

FIG. 13 shows a further embodiment of the invention. In this case, the sphere is located between two compression members 23 in the form of low friction ball bearings
20 such that the sphere can rotate freely, but with the centre of the sphere kept in place. The stators 14 can thus be pressed against the sphere with a predetermined force, however, the weight of the sphere does not influence the pressure of the sphere against the contact tips 3. The compression members can be located parallel with the stators as shown in the figure, but other locations, for example at right angles to the stators, are
25 also possible.

Also shown in FIG. 13 is an optional device 26, for example a camera or a robot arm, attached to the sphere 18. A device 26 can also be attached to the sphere 18 by connections means as for example a connecting rod.
30

FIG. 14 illustrates how several, in this case four, stators 14, preferably triangular stators, can be used for driving the sphere 18. In this case, the actuator is still operable,

even when some of the resonators 15 should fail. This is especially important in situations, where it is not possible to repair the actuator immediately, or where the reliability of the function of the actuator is essential, for example if such an actuator is used on a satellite.

5

To measure the angular position of the sphere, several methods are available. A first and simple method is to utilise a position sphere which is in contact with the sphere in the actuator. The position sphere with encoders works in a way very much like a position sphere in a computer mouse.

10

Another method is to provide the surface of the sphere in the actuator with a laser readable grid. The reflected laser beam, which is measured by a light detector, will then change the signal in the detector each time a border between the sectors in the grid is crossed.

15

A third method implies detection of reflected laser light. In this case the relative moving member may have a mirror attached to it, or be shaped as a sphere with a flat mirror part. A laser light reflection from the mirror part will change direction as the relative moving member is turned. The direction of the reflected beam can be measured very precisely with an array detector, for example a CCD (charge coupled device) detector with an area array of pixels. This very precise measurement of the orientation of the relative moving member is useful, when rotations of even very small angles have a great effect, for example during the orientation of a cameras or an antenna in a satellite or aircraft.

25

Another application of the vibration actuator is in the field of crystallography, where crystal orientations or strain in crystals is measured. Also in this case, a precise orientation measurement of the angular position of the relative moving member is necessary.

30

A further application is stabilisation of instrument platforms, for instance in an aircraft.

A still further application is in high flexible vehicles, where the sphere acts as a wheel.

CLAIMS

1. A vibration actuator with multiple degrees of freedom, comprising at least one vibration element (14) and a relative moving member (18),
5 wherein the vibration element (14) comprises
- at least one elastic member (15) which is plate shaped,
 - a driving force output member (3) attached to and projecting from the elastic member (15) at a predetermined position, and
 - at least two electromechanical converting elements (1, 6) attached to a surface of the elastic member (15), the electromechanical converting elements (1, 6) being excited by impressing driving voltages thereon to generate a motion of the elastic member (15) and thereby causing a driving movement of
10 the driving force output member (3),
- wherein the relative moving member (18) has a curved surface contacting the driving
15 force output member (3),
wherein the driving movement of the driving force output member (3) produces a relative motion of the relative moving member (18) with respect to the vibration element (14),
c h a r a c t e r i z e d i n
20 that the excitation of the electromechanical converting elements (1, 6) generates a vibration of the elastic member (15) which is a sum of partial vibrations, where each partial vibration is a bending vibration.
2. A vibration actuator according to claim 1 c h a r a c t e r i z e d i n that the vibration
25 is a sum of partial vibrations in the first and the second bending mode.
3. A vibration actuator according to claim 1 or 2 c h a r a c t e r i z e d i n that the relative moving member comprises at least part of a sphere.

4. A vibration actuator according to claim 1 - 3 characterized in that the elastic member comprises four electromechanical converting elements arranged in pairs on each side of the elastic member.
- 5 5. A vibration actuator according to claim 1 - 4 characterized in that the driving force output member on the elastic member is located between two electromechanical converting elements that are located on one side of the elastic member.
6. A vibration actuator according to claim 1 - 5 characterized in that the converting elements are piezoelectric elements.
- 10
7. A vibration actuator according to claim 1 - 6 characterized in that the vibration element is polygonal with each side of the polygon comprising an elastic member.
- 15
8. A vibration actuator according to claim 1 - 7 characterized in that the vibration element is triangular.
9. A vibration actuator according to claim 1 - 8 characterized in that the locations for the connections between the elastic members coincide with the location of nodes of the wave formed bend of the elastic members during the bending vibration.
- 20
10. A vibration actuator according to claim 1 - 9 characterized in that the vibration element further comprises at least one compression element.
- 25
11. A vibration actuator according to claim 1 - 10 characterized in that the vibration actuator comprises two vibration elements arranged parallel and in contact with the relative moving member.
- 30
12. Method of generating a vibration in an elastic member (15) which is plate shaped, where at least two electromechanical converting elements (1, 6) are attached to a surface of the elastic member (15), the electromechanical converting elements (1, 6) be-

ing excited by impressing driving voltages thereon to generate the vibration of the elastic member (15), characterized in that the vibration of the elastic member (15) is a sum of partial vibrations, where each partial vibration is a bending vibration.

5 13. Method according to claim 12 characterized in that that the vibration is a sum of partial vibrations in the first and the second bending mode.

10 14. Method according to claim 12 or 13 characterized in that that the elastic member (15) constitutes part of a vibration actuator with multiple degrees of freedom, where said vibration actuator comprises at least one vibration element (14) and a relative moving member (18), wherein the vibration element (14) comprises said elastic member (15) and a driving force output member (3) attached to and projecting from the elastic member (15) at a predetermined position, where the vibration of the elastic member (15) causes a driving movement of the driving force output member (3).

15

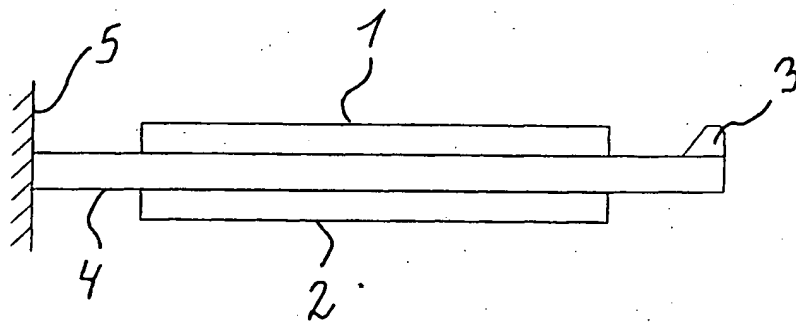

FIG. 1

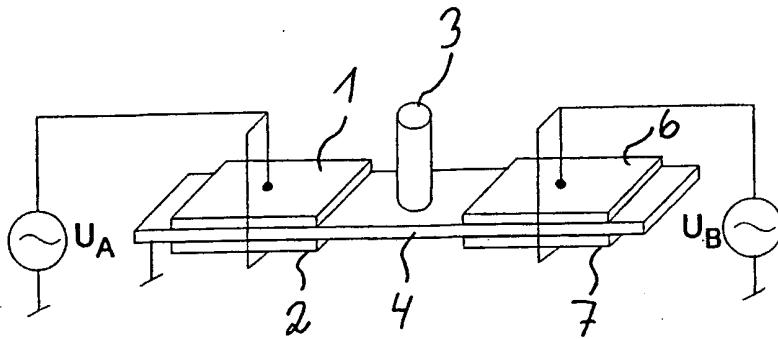

FIG. 2

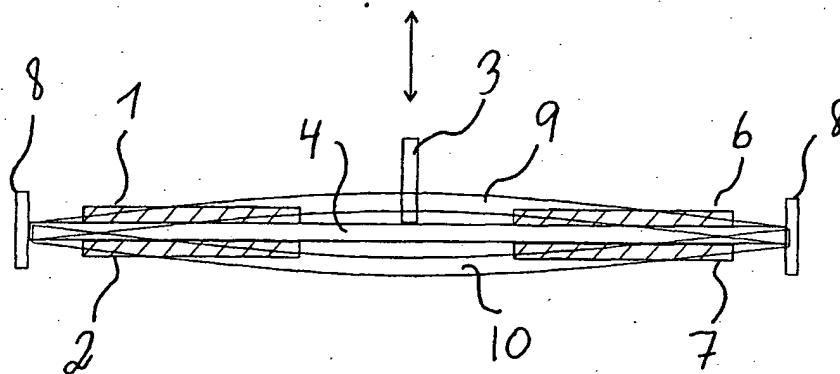

FIG. 3

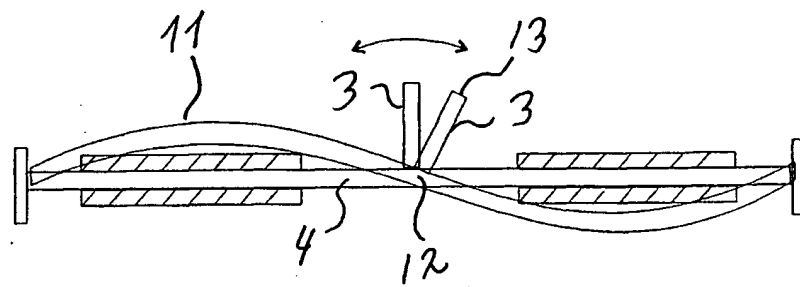

FIG. 4

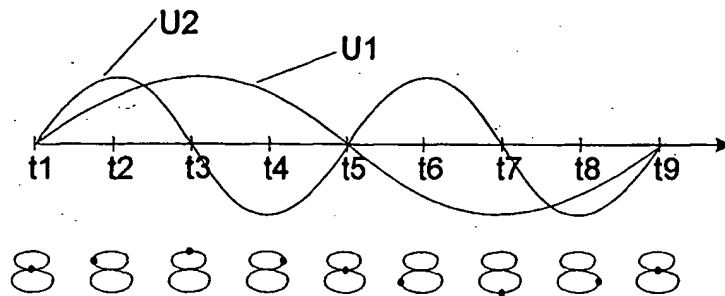

FIG. 5

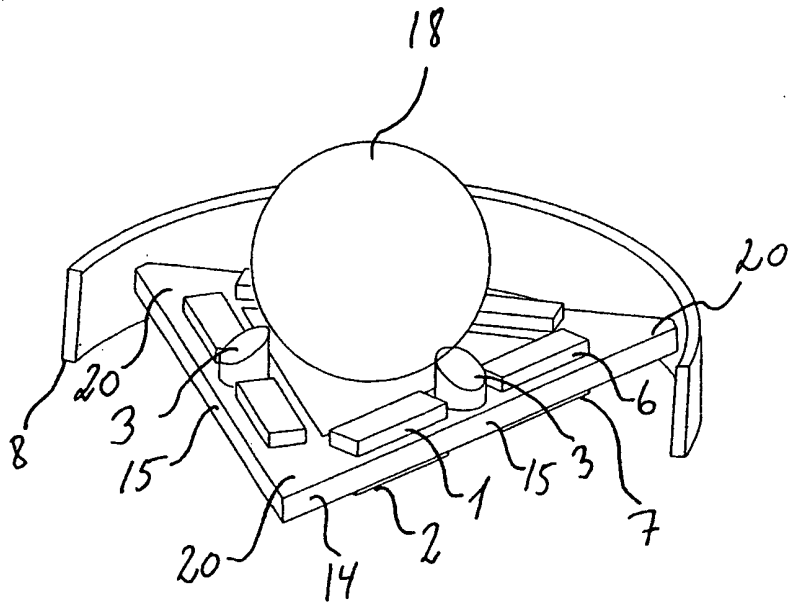

FIG. 6

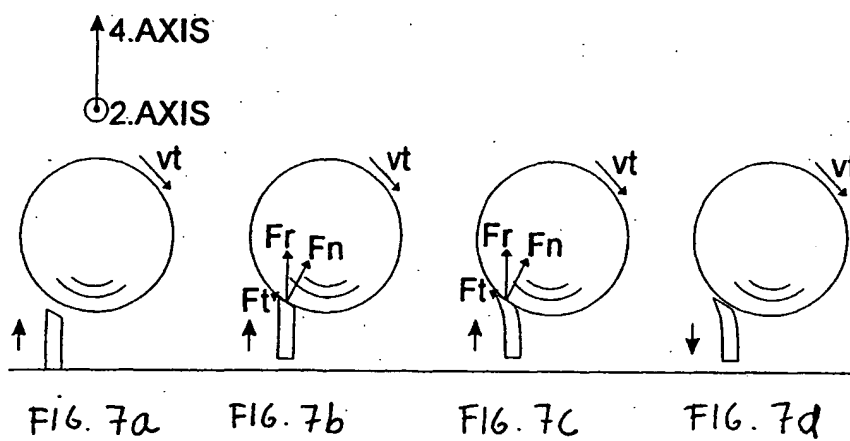

FIG. 7

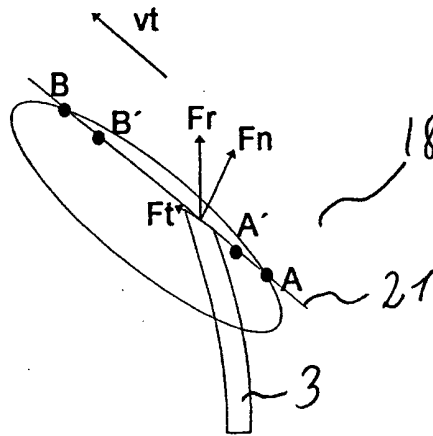

FIG. 8

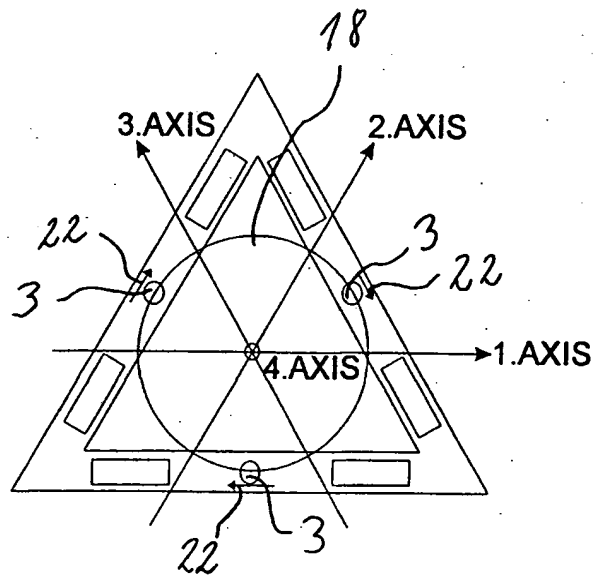

FIG. 9

10/14

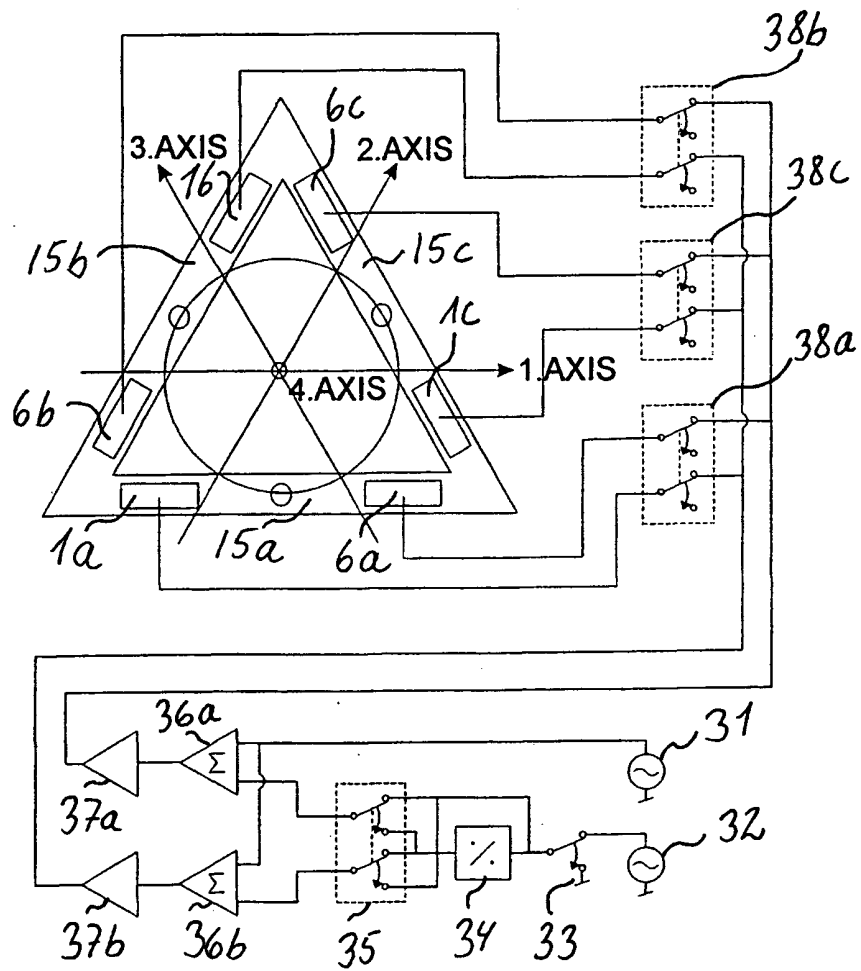

FIG. 10

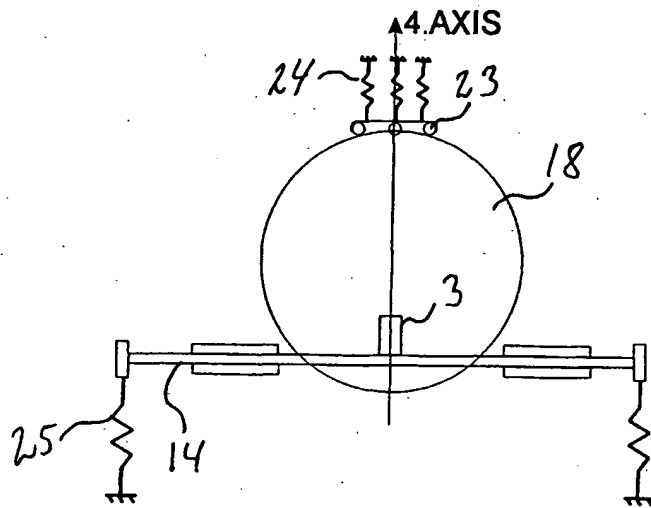

FIG. 11

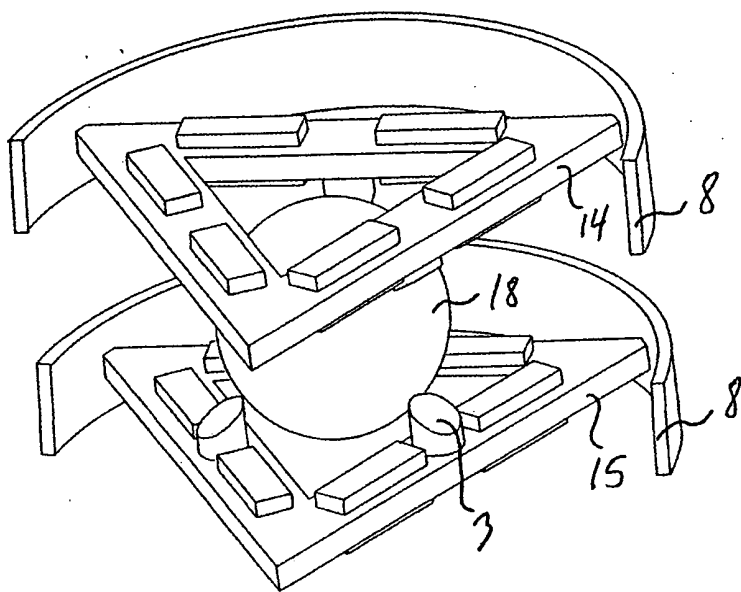

FIG. 12

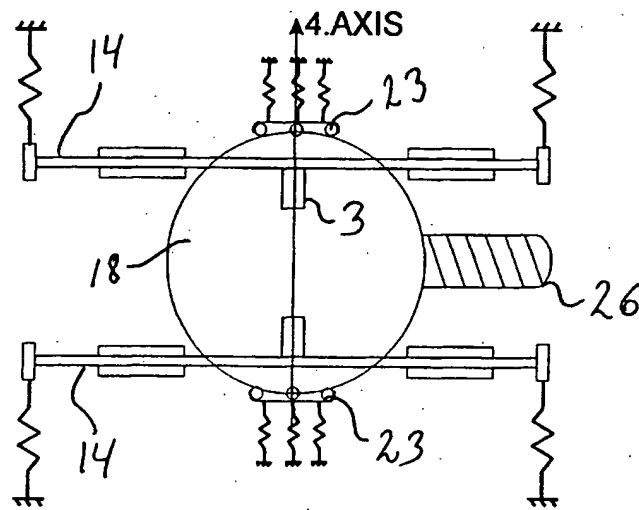

FIG. 13

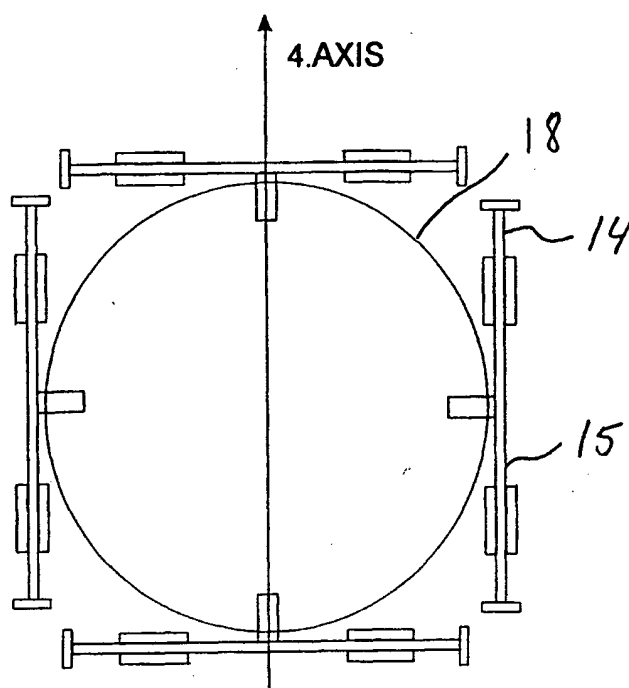

FIG. 14

INTERNATIONAL SEARCH REPORT

International Application No

PCT/DK 99/00626

A. CLASSIFICATION OF SUBJECT MATTER IPC 7 H01L41/09 H02N2/00		
According to International Patent Classification (IPC) or to both national classification and IPC		
B. FIELDS SEARCHED		
Minimum documentation searched (classification system followed by classification symbols) IPC 7 H01L H02N		
Documentation searched other than minimum documentation to the extent that such documents are included in the fields searched		
Electronic data base consulted during the international search (name of data base and, where practical, search terms used)		
C. DOCUMENTS CONSIDERED TO BE RELEVANT		
Category *	Citation of document, with indication, where appropriate, of the relevant passages	Relevant to claim No.
P,X	EP 0 923 144 A (CANON KK) 16 June 1999 (1999-06-16) page 13, line 10 - line 30; figures 24A-24D	1-3,5,6, 12-14
P,A	--- US 5 872 417 A (SUGAYA ISA0) 16 February 1999 (1999-02-16) cited in the application column 7, line 35 -column 11, line 18; figures 2,3 abstract	1-14
A	--- EP 0 718 899 A (NIPPON KOGAKU KK) 26 June 1996 (1996-06-26) the whole document ---	1-9,12
-/--		
<input checked="" type="checkbox"/> Further documents are listed in the continuation of box C.		
<input checked="" type="checkbox"/> Patent family members are listed in annex.		
* Special categories of cited documents :		
A document defining the general state of the art which is not considered to be of particular relevance *E* earlier document but published on or after the international filing date *L* document which may throw doubts on priority claim(s) or which is cited to establish the publication date of another citation or other special reason (as specified) *O* document referring to an oral disclosure, use, exhibition or other means *P* document published prior to the international filing date but later than the priority date claimed		
T later document published after the international filing date or priority date and not in conflict with the application but cited to understand the principle or theory underlying the invention *X* document of particular relevance; the claimed invention cannot be considered novel or cannot be considered to involve an inventive step when the document is taken alone *Y* document of particular relevance; the claimed invention cannot be considered to involve an inventive step when the document is combined with one or more other such documents, such combination being obvious to a person skilled in the art. *8* document member of the same patent family		
Date of the actual completion of the international search <p style="text-align: center;">2 March 2000</p>		Date of mailing of the international search report <p style="text-align: center;">06.04.00</p>
Name and mailing address of the ISA European Patent Office, P.B. 5818 Patentlaan 2 NL - 2280 HV Rijswijk Tel. (+31-70) 340-2040, Tx. 31 651 epo nl, Fax: (+31-70) 340-3016		Authorized officer <p style="text-align: center;">Bo Gustavsson</p>

INTERNATIONAL SEARCH REPORT

Intern. Patent Application No
PCT/DK 99/00626

C.(Continuation) DOCUMENTS CONSIDERED TO BE RELEVANT		
Category *	Citation of document, with indication, where appropriate, of the relevant passages	Relevant to claim No.
A	PATENT ABSTRACTS OF JAPAN vol. 015, no. 039 (M-1075), 30 January 1991 (1991-01-30) & JP 02 276741 A (TAMURA ELECTRIC WORKS LTD), 13 November 1990 (1990-11-13) abstract ---	1,5,6,12
A	PATENT ABSTRACTS OF JAPAN vol. 1996, no. 09, 30 September 1996 (1996-09-30) & JP 08 126358 A (NIKON CORP), 17 May 1996 (1996-05-17) abstract -----	1,5,6,12

INTERNATIONAL SEARCH REPORT

Information on patent family members

International Application No

PCT/DK 99/00626

Patent document cited in search report	Publication date	Patent family member(s)	Publication date
EP 0923144 A	16-06-1999	JP 11164576 A	18-06-1999
		JP 11220891 A	10-08-1999
		JP 11220893 A	10-08-1999
		JP 11220892 A	10-08-1999

US 5872417 A	16-02-1999	JP 9219980 A	19-08-1997

EP 0718899 A	26-06-1996	JP 8182351 A	12-07-1996
		JP 8331874 A	13-12-1996

JP 02276741 A	13-11-1990	NONE	

JP 08126358 A	17-05-1996	DE 69507857 D	25-03-1999
		DE 69507857 T	19-08-1999
		EP 0691692 A	10-01-1996
		US 5917268 A	29-06-1999

BLANK PAGE